

**The Freshwater Institute
Natural Gas Powered
Aquaponic System - Design Manual**

September 1997
Version 1.3

**TCF-Freshwater Institute
1098 Turner Road
Shepherdstown, WV 25443**

TCF-Freshwater Institute
1098 Turner Road
Shepherdstown, WV 25443
Phone: 304-877-0815
Fax: 304-877-0815
E-mail: info@tcf-freshwater.com
Web: www.tcf-freshwater.com

ACKNOWLEDGEMENTS

This system design manual was prepared by The Conservation Fund's Freshwater Institute with grants from The Consolidated Natural Gas Foundation and The Claude Worthington Benedum Foundation.

We would like to recognize the tremendous cooperation of Steve Bogash of the University of Maryland Cooperative Extension Service in Keedysville, Maryland for providing greenhouse design and management support and for contributing to the writing and editing of this manual.

TABLE OF CONTENTS

Acknowledgements	2
Purpose	4
Introduction	5
Overview of System Design and Operation	5
Site Requirements	7
Greenhouse Design.....	7
Greenhouse Heating and Cooling.....	8
Other Infrastructure	9
Growing Beds.....	9
Pumps and Irrigation System.....	13
Aeration System	16
Root-Zone Heating System	17
Control and Monitoring Systems	18
Overview of System Construction	18
System Initialization.....	18
System Management	19
Insect Control	19
Water Quality Management Issues.....	20
Fingerling Sources.....	23
Other Issues	23
Appendix A: Parts List.....	25
Appendix B: Additional Resources.....	33
Appendix C Estimated Operating Costs.....	36

PURPOSE

The purpose of this operator's manual is to provide those interested in aquaponics with a technical description of the design and operation of the commercial scale aquaponics system installed in Tallmansville, West Virginia. The manual assumes a familiarity with aquaculture and greenhouse production. A system operator should be knowledgeable about both aquaculture and greenhouse production.

This is strictly a system design manual, it is strongly recommended that all necessary business and personal matters be considered thoroughly prior to construction of an aquaponic system. As with all new ventures a marketing/business plan, enterprise budget, and cash flow analysis are necessary evaluation tools.

Call your local County Extension Service Office for assistance in any evaluation. Also, the Northeast Regional Engineering Service (NREAS) offers NRAES publication #32 titled: "Farming Alternative: A Guide to Evaluating the Feasibility of New Farm-Based Enterprises" as an aid in new enterprise evaluation. This is also available through your local County Extension office. The cost of this publication is \$8.00.

Introduction

An integrated recycle aquaculture-hydroponics (aquaponics) vegetable system was developed by the Freshwater Institute to demonstrate the technical and economic feasibility of using natural gas from shut-in gas wells for alternative agricultural activities. The system was installed in the spring of 1996 and has been in operation since May 1996. The system, which cost \$38,632 to build, was designed to produce about 950 lbs of tilapia and 7,000 to 10,000 lbs of mixed vegetables and herbs per year.

The Freshwater Institute based the design for the Tallmansville aquaponics system on a design provided by S&S Aquaculture (West Plains, Missouri), a commercial producer of fish and hydroponic herbs and vegetables and on research conducted at North Carolina State University (McMurtry, 1989; McMurtry et al., 1990). For the Tallmansville site, the Freshwater institute modified the aquaponics system further to simplify and reduce pumping, improve heat and oxygen transfer, remove solids more effectively, and to take advantage of the low cost natural gas.

The Tallmansville aquaponics system was developed to be capable of producing a wide variety of leafy vegetables and herbs. The demonstration system operator has focused plant production on basil, rosemary, and specialty lettuces based on an analysis of local market conditions. The system is scaled to facilitate niche marketing of the fish and plants, which are both sold locally at premium prices and not in competition with large out-of-state growers at the wholesale level.

Tilapia were selected for production because the fish grow fast, are very hardy, are tolerant of crowding and relative poor water quality conditions, and are resistant to many diseases that have troubled other cultured finfish. In addition, tilapia tolerate temperatures ranging from 50-100°F and grow well at temperatures > 68°F (Rakocy, 1989), which encompasses the temperature regime favorable for plant production. Tilapia are also readily marketed locally because they are popular with the restaurant and grocery store trade, with a firm and flaky flesh, and a mild flavor.

Overview of System Design and Operation

The integrated aquaponic system consists of two independent rearing loops with one fish tank and six vegetable/herb growing beds per loop (Figures 1 and 2). Water is pumped from the fish tanks to the gravel growing beds for about eight minutes every twenty-two minutes. During the pumping cycle, water fills each gravel bed before gravity draining back to the fish tanks during the remainder of the cycle while the pump is off. The gravel growing beds are designed to serve as both a biofilter and as the primary heat exchanger for the system. A root zone heating system is buried in the gravel. Bacteria in the gravel convert toxic ammonia to nitrates which are then taken up by the plants. The ebb and flow water supply is designed to provide nutrients to the plants during the flooding cycle and provide aeration within the gravel bed during the draining cycle. The

system is completely closed with make-up water manually added to compensate for evapo-transpiration and evaporation from the tanks.

The ratio of fish culture volume to gravel growing bed volume for the system is about 1.3 to 1. Although the volumetric ratios reported in the literature vary significantly, we recommend a ratio close to 1:1 in order to provide an adequate level of filtration (both biological and physical filtration) in the gravel beds and to distribute the hydraulic load. The scale of the system is set in part by the projected local market for fish and mixed produce.

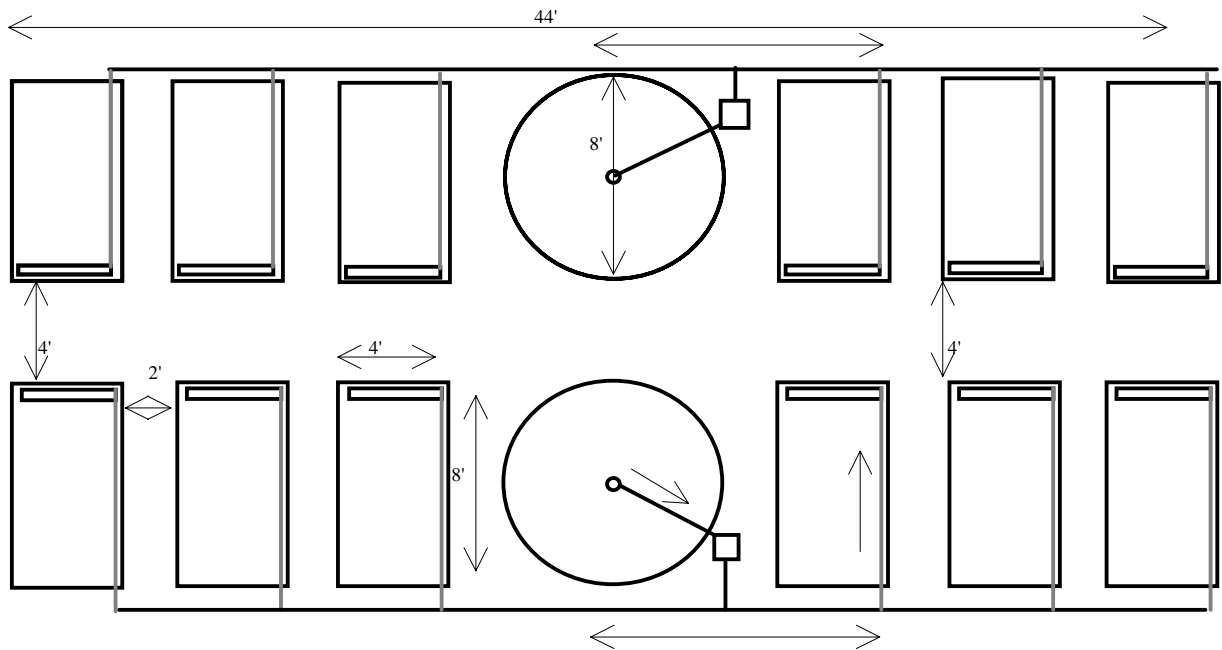

Figure 1 Overview of the irrigation system.

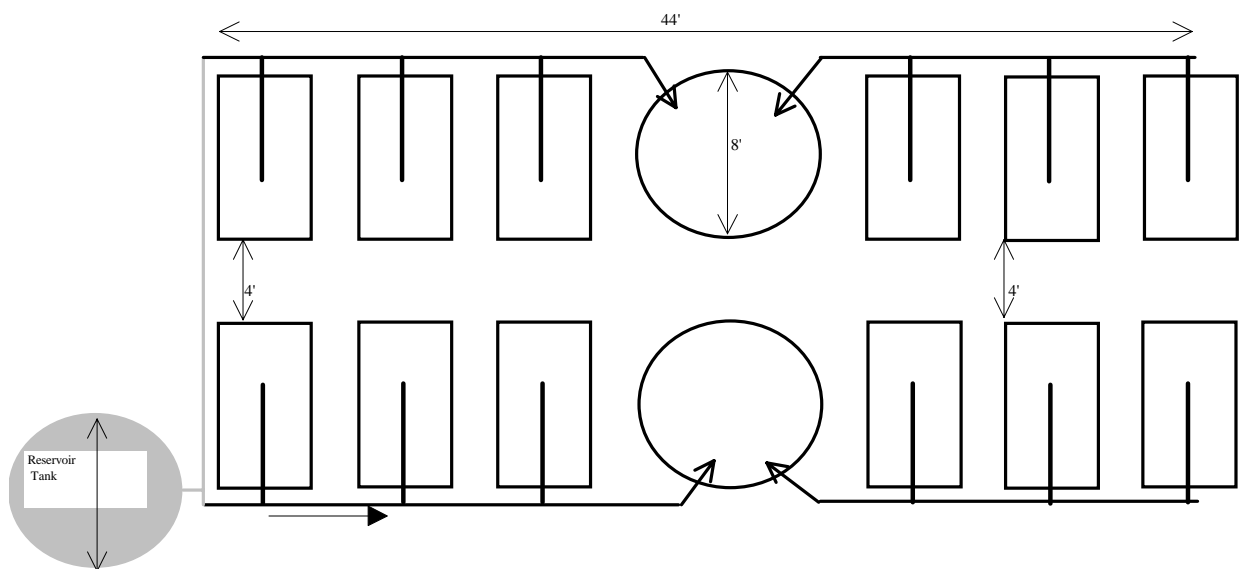

Figure 2 Overview of the return flow lines.

Site Requirements

The minimum site requirements for this aquaponics system include access to water, electricity, and heat (e.g. natural gas, oil, or propane), and a level space of at least 64' by 30'. The water source does not have to be high volume; for example, the spring source for the Tallmansville site only produces 5 gpm. Potential incoming water sources include springs, wells, and public water supplies. In some cases, public water supplies will have to be dechlorinated before use. A water supply should be tested for the following and other parameters before a site is finally selected: pH, oxygen, alkalinity, hardness, suspended/dissolved organics, inorganics (particularly iron and manganese), and pesticides (see section on water quality management for further information). A local extension office or the local NRCS agent can be contacted about a site evaluation or to arrange for a water quality analysis. If a site has a risk of potential ground/surface water contamination, then it should not be selected.

Greenhouse Design

This Tallmansville aquaponics system is housed inside a 50' x 64' (3,200 ft²) gutter-connected greenhouse (the system will fit into a 30' x 64' area) with a gravel floor and metal frame (see Figure 3). The roof and south wall of the greenhouse are constructed from a double layered 6 mil plastic. The inner north wall is constructed out of double layered plastic at the top and 8 mm PCSS clear panels from trusses to the floor. The outer wall is built with a single layer of plastic on top and micro-screen on the side (Figure 3). Use of micro-screen to prevent the introduction of insects is recommended , as are natural insect control strategies, because most pesticides cannot be used in an integrated plant-fish system without adverse effects on fish health. Appendix B contains information on pest control and screen designs.

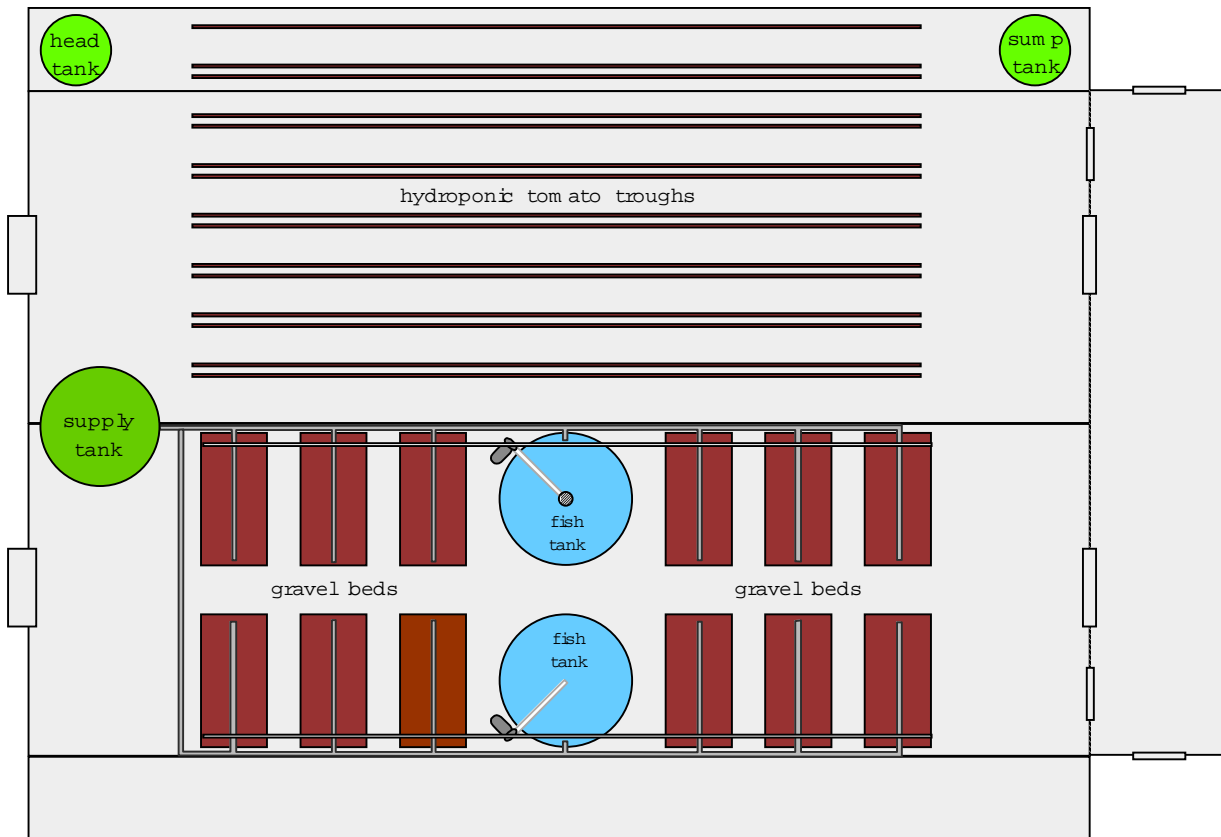

Figure 3 Overview of greenhouse layout at demonstration site.

To minimize capital costs and facilitate construction of the aquaponics system, gravel is used for the greenhouse floor. A 4" layer of small ½" to ¾" gravel is placed on a geotextile liner (to prevent mud from coming up through the gravel). Use of a gravel floor allows the incoming water line and the plumbing associated with the root zone heating system to be buried. The gravel is contained at the greenhouse perimeter by 2" by 10" pressure treated lumber attached to the greenhouse frame.

The system is centered on one side of the gutter-connected greenhouse. This provides a 4' center aisle, 5' aisles down the sides and 2' aisles between beds. This also leaves approximately 10' at either end for the water storage and heating systems, seedling propagation bed, and miscellaneous equipment storage space.

Greenhouse Heating and Cooling

The primary source of heat for the system is a root zone heating system (described below in the section on gravel bed construction). An overhead forced air system is also installed as a back up.. System cooling is achieved through the use of a 70% shade cloth and standard exhaust fans and louvers with a temperature control unit.

Other Infrastructure

Water Resource: A small spring serves as the primary water source for the system. Water is pumped from the spring via a 110 volt 3/4 hp submersible water pump to a 1100 gallon vertical storage tank located in the greenhouse. The size of the water pump could vary depending on the distance from the spring to the greenhouse, and the head pressure that must be pumped against. A float switch in the storage tank turns the sump pump on and off, ensuring that the storage tank will automatically fill. The storage tank is set on two rows of 8" cement blocks to provide sufficient head pressure to drain the tank. The addition of make-up water is controlled by 2" valves next to the beds closest to the reservoir tank. The 2" PVC incoming make-up water line is plumbed into the 2" drain line that returns water from the gravel beds to the fish tanks (Figure 2).

For information on how to develop a spring source, contact the local county extension service or Natural Resource Conservation agent.

Electricity: All electricity for the system is provided by a natural gas-to-electric generator. Back-up power is provided by a manual switch to transfer the system to the city power grid. An alarm (such as a sensa-phone) is recommended to alert the system operator in case of generator failure.

Growing Beds

The 4' x 8' growing beds are constructed of treated 3/4 inch plywood sheet and 2 x 12" boards. The growing beds are reinforced with a 2 x 4" frame across the bottom with boards every 2 feet to more evenly carry the weight. The beds are screwed together, not nailed. The beds are caulked and painted inside and out with a flat white waterproof paint (not oil-based).

The growing beds are lined with plastic to prevent wood rot (see Picture 1). The liners are stapled to the outside edges of the growing beds. Heavy duty plastic or rubber (backyard pond liners) for fabricating bed liners can be obtained from garden supply centers or ordered directly from the manufacturers. Several sources are listed in Appendix B.

The gravel beds are elevated 24" on three 8" concrete blocks to facilitate construction of the drain lines and to provide a comfortable working height (Figure 4). The concrete blocks are set on 16" x 16" patio stones to prevent the blocks from settling in the gravel. Two 1-1/4" thick, 6" wide, and 16" long shims are placed at the top end of the bed between the blocks and the bed frame to promote drainage. One 3/4" thick shim is placed on the middle row of blocks. The shims raise the end of the bed, which receive the water flow, about 2" higher at the top than at the drain end.

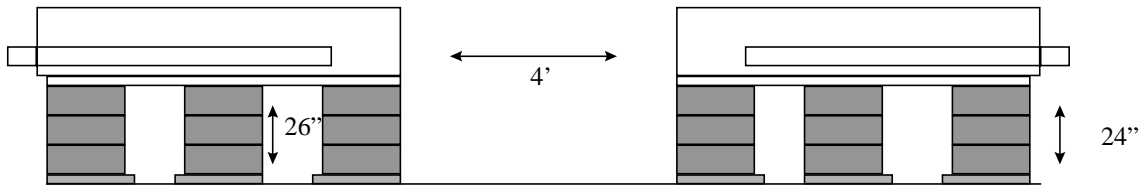

Figure 4 Side view of the raised beds set on paving stones with measurements. Note the shims are not shown in the figure.



Picture 1 Illustration of the 20 mil plastic bed liner and bulk head fitting and well screen - drain.

Collection drains are constructed of 5' lengths of 2" diameter PVC well screens with 0.40" slots (with 2" diameter PVC end caps) cemented to a 2" bulkhead fitting on the lower end of the bed. As shown in Picture 2, the bulkhead fitting are inset into the center of the 4' long, 2"x12" wall at the low end of the bed. Silicone caulking is used to improve the seal between the bulkhead fitting and plastic bed liner.



Picture 2 Illustration of the 2” bulkhead fitting set into the outside of the bed wall.

A short piece of 2” PVC is cemented to the bulkhead fitting and then to a 2” PVC sweep-tee. A 2” female adapter with a threaded plug was placed (not cemented) on the end of the sweep-tee. By not cementing the end cap, one can access the drain line and using a piece of doweling, scrape out any roots or sludge that are likely to build up in the well screen over time.

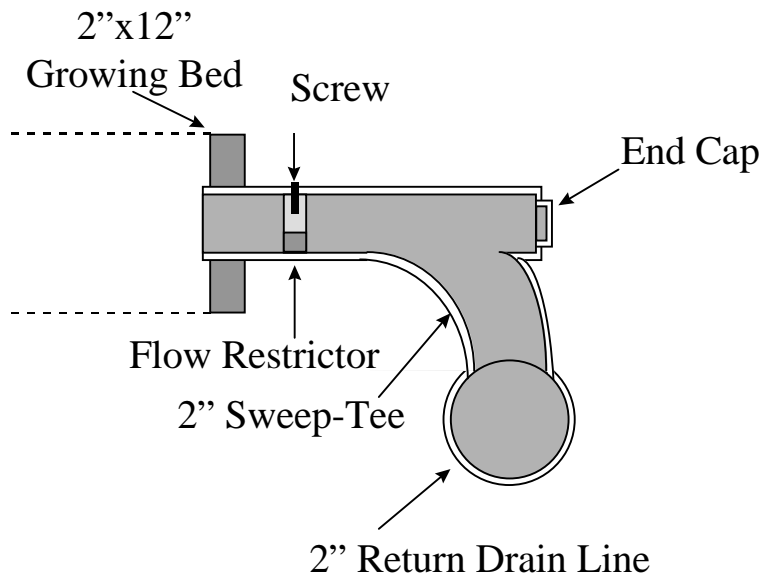

Figure 5 Illustration of the flow restrictor set in the drain line coming from the low end of the growing beds. The drain line is set in the 2” X 12” endwall.

To control the rate of flow back to the tanks, a flow restrictor (a circular donut/washer made from ¼” thick PVC plate) is set in the 2” drain line between the bulkhead fitting and the sweep-tee (see Figure 5). A 1” hole is drilled into the bottom of

the flow restrictor. A screw pilot hole is drilled through the top of the drain and into the flow restrictor allowing the piece to be secured in the drain. The flow restrictor reduces the flow rate from the bed, which fills the bed in about 8 minutes.

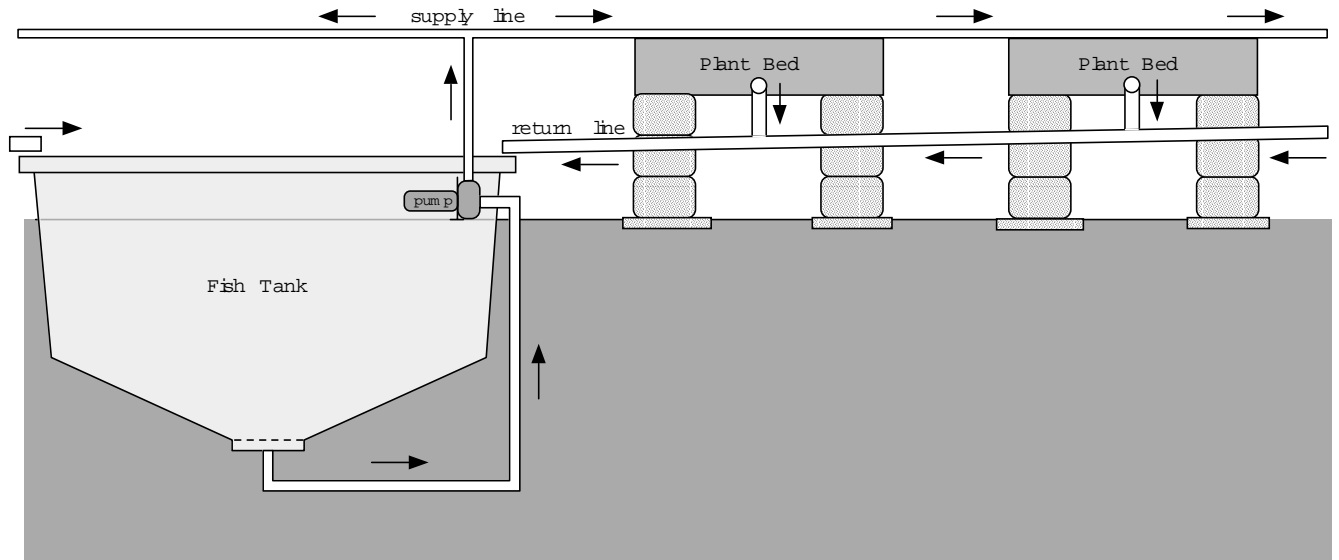

Figure 6 Illustration of the water flow to and from the plant beds.

The gravel growing beds drain into a 2" PVC drain line that carries the water back to the fish tank (Figure 6). A short section of 2" PVC pipe is used to connect the sweep-tee to the drain line. The actual length of the 2" section of PVC pipe depends on the drop to the culture tank. A minimum slope of 2% (1/4" per ft) from the outer bed to the tank is used to facilitate return flow to the tanks. To provide additional flexibility to the return flow line, two 2" flexible adapter fittings (Fernco couplings) are used to join the 2" drain line from the beds to a 45° 2" elbow and a short section of 2" PVC piping resting on the edge of the tank.



Picture 3 Illustration of the root-zone heating system buried in the gravel beds. Note boards were used to hold down the plastic tubing when filling the beds with gravel.

A #8 river-run, washed, pea gravel (approximately ¼”) is used as the growing media in the beds. A first layer of gravel is placed in the beds so that it just covers the well screen and then the Root-Zone heating system is laid out on the gravel (Picture 3) (See section Root-Zone heating system for further information). The beds are then filled with gravel to within 1” of the top. The gravel is further washed in the beds and the effluent allowed to drain out of the system (not into the fish tanks).

Pumps and Irrigation System

The fish rearing tanks are polyethylene tanks 8’ diameter and 57” tall, with a conical bottom, that provides an operating volume of 950 gallon. Tank size is based on the projected local demand for fish and vegetables/herbs. Use of two independent systems, rather than one larger system, reduces the risk of catastrophic losses from disease, mechanical failure, operator error, etc.

Dig holes for the tanks prior to spreading the gravel for the floor and construction of the greenhouse frame. Set the tanks approximately 45” into the ground to insulate and support the tanks, which avoids purchasing metal or wood tank stands, and allows easy

drainage from the beds (Figure 6). Prior to placing the tanks in the ground: (1) a 2” bulkhead fitting is attached to the bottom of the tank; (2) the drain lines are attached to the bottom of the tank and run out past the edge of the tank and then elbowed to bring the drain line up to just below the 2” union joint coming off the intake point on the pump; and, (3) the drain covers are set in place.

To reduce the potential damage to the drain piping that can be caused by tank settling, a pair of PVC compression couplings should be spaced evenly in the horizontal portion of the drain line. Silicone caulking should also be used to prevent the bulkhead fittings from leaking. Drain covers can be made from a circular piece of polyethylene perforated with 1/4” holes. To prevent the tanks from potentially floating up, the tanks should be filled with water as soon as the space around the tanks is filled with gravel.

All pumps are 1 hp Pak Fab Challenger - medium head pumps. This pump is commonly used for swimming pools and is readily available. The pump has a basket filter which keeps gravel and other debris out of the pump. The pumps are wired to 60 minute timers which turn them on for 8 minutes every 30 minutes (see monitoring and control section).

The pump sits next to the 950 gallon rearing tank (Figure 5). The pump intake connects to the culture tank drain line and the pump discharge connects to the plant bed irrigation system. Union joints are installed at the pump intake and discharge points to facilitate quick pump replacement for maintenance and repair. Because no hard surfaces are available to mount equipment on a gravel floored greenhouse, the pumps are mounted to a pump frame constructed on a 17” x 21” concrete chimney block. The pumps are attached to two anchor bolts set in concrete within the chimney block’s flue cavity. A wood frame is attached to the chimney block to brace water and air pipes and to mount the blowers.



Picture 4 Illustration of the pump frame.

Water is pumped to the beds first passing through a union joint, check valve, ball valve, and gate valve (Picture 4). After the 2" union joint following the pump, a reducer coupling is installed to bring the pipe to 1-1/2". A 1-1/2" check valve is installed in the vertical section of irrigation line to prevent backflow. A ball valve is installed on each bed to rapidly shut-off flow without disturbing the flow throttling set at the gate valve. The vertical section of pipe extending above the pump is long enough so that the 1-1/2" PVC Tee that splits the flow between the two sections of beds is even with the tops of the growing beds. In addition, a 1" gate valve is installed to provide fine adjustments to the pump discharge flow.

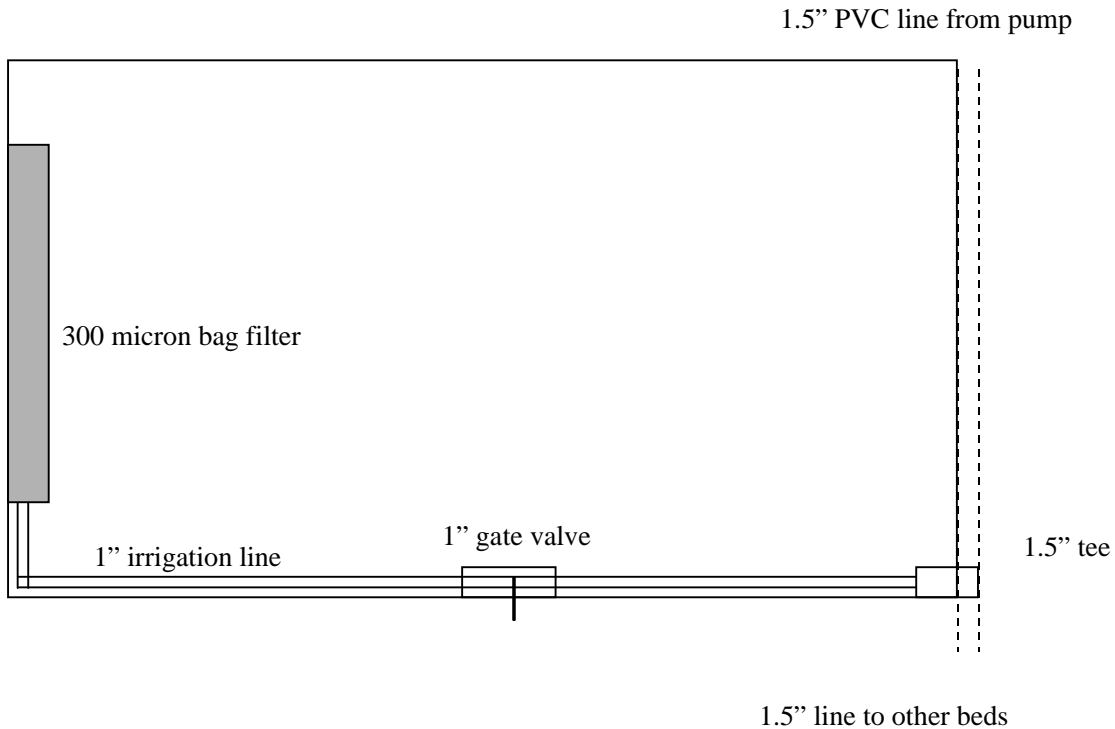

Figure 7 Overview of growing bed irrigation system.

A 1-1/2" ball valve is installed on either side of the 1-1/2" PVC tee to control flow to the three beds on either side of the tank. The 1-1/2" PVC line, as it travels across the ends of the beds, is interrupted by a 1-1/2" PVC tee at the corner of each bed to bring flow to each bed. The line to each bed is reduced to 1" and a gate valve is installed to allow for flow adjustments (Figure 7). The line runs to a 90° elbow at the end of the bed with the highest elevation. The gravel is then irrigated through a 300 micron bag filter which catches unwanted solids. The 1" line coming off the 1.5" Tee is dry fit (not glued) to allow for periodic dismantling and cleaning. The filter bags are clamped on to facilitate easy removal for daily cleaning.

Aeration System

In this system, dissolved oxygen is typically the first limiting parameter for the fish. Dissolved oxygen is provided by aeration. Without aeration, dissolved oxygen levels would quickly drop to levels that could kill fish. The fish tanks are aerated by a 1/2 horsepower regenerative blower coupled to air stones and air lift pumps placed in each culture tank. Aeration also strips unwanted carbon dioxide from the water. A back up blower is installed and duty is switched between the two on a regular basis.

Air is delivered to the tanks via a 2" PVC line that feeds into a 2" PVC octagonal manifold that surrounds the edge of each tank. Air stones (medium pore diffusers), attached by vinyl tubing to the air manifold, hang in the tank. The air stones create small bubbles to allow for more efficient diffusion of oxygen into the water. The air stones are

hung deep enough so that they are still submerged when the water level drops during the pumping cycle.

The aeration provided is (and must be) sufficient to maintain dissolved oxygen levels greater than 4 mg/l (ppm) at all times (assuming current stocking densities). Because fish consume more oxygen just after feeding, dissolved oxygen levels are (and should be) checked after feeding.

The blowers are switched and routine maintenance performed monthly.

Root-Zone Heating System

The primary heat source for the system is a root-zone heating system buried in the gravel beds (Figure 7). Root-zone heating technology is commonly used in the greenhouse industry to provide heat directly to a plant's root zone, allowing a greenhouse operator to maintain a lower greenhouse air temperature. This can result in significant energy cost savings. Typically, a greenhouse operator will bury the rubber tubing in the floor beneath the plants and recirculate hot water through system.

In the Tallmansville aquaponics system, the gravel beds are heated to about 80°F; this heat is transferred to the culture water when the gravel beds are flooded. Heating the gravel beds results in a constant water temperature in the culture tanks of 75 to 80°F. Supplemental heating of the building air is only required when the outside temperature dropped below 40°F.

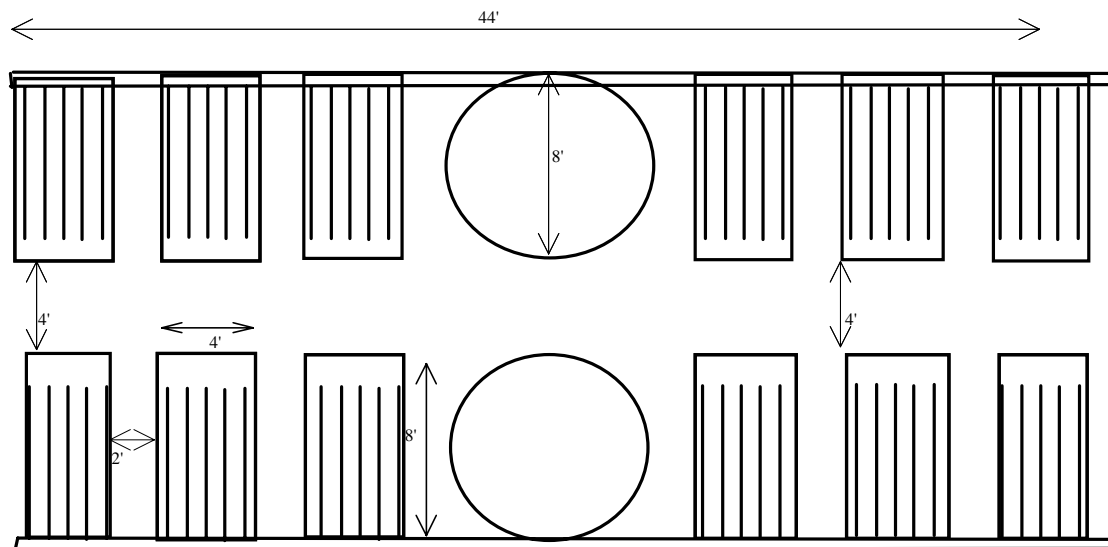

Figure 8 Overview of root zone heating system.

The root-zone heating system installed at the Tallmansville site is custom fabricated by Bio-Energy Systems, Inc. Each bed contains a 4' x 8' pre-assembled tubing module (Figure 8). All the beds are plumbed to a central hot water distribution system via 1-1/2"

schedule 40 PVC line. The distribution system for the two aquaponic systems is linked to the water heater system/recirculation pump via 1" metal piping which is buried in the gravel. Water is heated using a 40 gallon natural gas water heater, held within a 42 gallon surge/expansion tank, and recirculated through the root-zone heating system by a Grundfos 26-96 circulation pump (specified by Bio-Energy Systems, Inc.). The water heater, expansion tank, and miscellaneous plumbing were purchased at a local hardware store. The root-zone heating system is set to maintain a temperature of 80°F in the gravel beds. A temperature probe, attached to the system thermostat is placed in one of the beds and provides feedback for the entire system.

Control and Monitoring Systems

Power to the recirculation pumps is run through two 60 minute repeat-cycle timers; one per pump. Separate timers are used for each pump to provide additional flexibility in case different crops require different flooding intervals. The timers are set to turn the pumps on every 22 minutes for 8 minutes. The time required to flood the beds depends on the pump capacity, plumbing layout, and number of beds. The flood time and pump rate are adjusted in each aquaponic system to provide the desired bed flooding.

Float switches are installed in the tanks to shut off the pumps if the water level were to drop below a predetermined level; this is a safety feature that ensures that the fish always have water.

To ensure that culture tank aeration never fails, a pressure sensitive switch in the air blower line is set to automatically turn-on the back-up blower in the event of a primary blower failure. Check valves after each blower prevent the blown air from escaping through the inoperative blower.

A "Sensa-Phone" brand alarm and auto-dialing unit is used to monitor for alarm conditions within the facility. The "Sensa-Phone" is set to call a series of phone numbers (programmed by the operator) and report on the following emergency conditions: power failure, blower failure, low fish tank water levels, and extremes in air temperature.

Overview of System Construction

Prior to construction of the greenhouse, the holes for the fish tanks should be dug and the site leveled. Once the tanks have been installed and the greenhouse footer is constructed, the gravel floor should be poured and leveled. Once the gravel is leveled off, the paving stones should be laid out according to the system design selected for the site. After the gravel growing beds have been constructed, the system can be plumbed in as described above.

System Initialization

The system should be started up two to three weeks prior to stocking with fish or plants. Running the system for several weeks prior to stocking and planting allows you to

check for leaks and to properly calibrate the flow to the beds, and to develop the bacteria colony in the beds. Bacteria in the gravel and fish will provide the inoculant to develop the bacteria culture in the growing beds. To ensure that the beds flood evenly, flow rates to the individual beds should be adjusted using the 1' gate valves on each bed and the 1-1/2" ball valve located above the pump.

Once the system is operating properly, fingerlings and seedlings can be added. We suggest that the system is stocked gradually to ensure that the fish do not overwhelm the capacity of the bacteria in the gravel beds to convert the fish waste. The beds should also be planted over a several week period to ensure that there are adequate nutrients available for the plants and to facilitate a continuous harvesting schedule for the plants.

System Management

Every month, fifty 0.1 lb (50 gram) tilapia fingerlings are stocked into each tank and 75 lbs of 1.0-1.5 lbs fish are harvested at steady state. After steady state production is achieved, it is projected that the facility will produce about 950 lbs of market size tilapia annually.

The twelve growing beds are planted with a mix of basil, rosemary, and specialty lettuces. The beds are seeded over several weeks to facilitate the continuous harvesting of plant material and to maximize nutrient removal. Production of basil, rosemary, and lettuce occurs year round, with a new crop coming off about every 7 days. The basil plants are cut back three times before replanting. The rosemary plants, which are perennials, are replaced when regeneration rates slow down. The specialty lettuces are harvested every 20 to 30 days. Supplemental nutrients are added (as needed) by foliar application to make up for micro-nutrient deficiencies in the fish feed. For basil, rosemary, and lettuce, a conservative estimate of plant production yields is 20 lbs of plant material per ft²; this results in a total system yield of 7,680 lbs per year. A similar commercial system in Missouri (S&S Aquaculture) reported mixed produce output levels of 47-164 lbs per ft² per year.

Insect Control

The system operator has implemented an integrated pest management plan (IPM) to reduce potential losses from insects and plant diseases. IPM is essential to the integration of the two production systems, because the presence of the fish in the recirculating systems prevents the system operator from applying insecticides or herbicides to the plants. A micro-screen air filter is installed to keep pests from entering the greenhouse through the air intake fans.

To reduce the introduction of plant pests and diseases within the system, all plant material should be propagated from certified seed and the operator should implement IPM practices. For further information on IPM and insect control in greenhouses see Appendix B or contact your local extension agent.

Water Quality Management Issues

Providing the fish with an environment conducive to optimal growth is the objective of a good water quality management program. Managers have a great number of tools at their disposal to predict, detect, and resolve water quality problems in systems that treat and reuse water. Paramount is careful monitoring and organized recording of vital water quality parameters is essential.

Many water quality variables fluctuate throughout the day. It is a good practice to take the measurements in the same place and at about the same time each day to make comparisons of data more valid.

Temperature - The temperature should be monitored about every other day. Tilapia grow best between 77 and 95°F. Tilapia become stressed and may die when water temperatures drop below 65° and 55° Fahrenheit respectively.

Dissolved Oxygen - Dissolved oxygen (DO) concentrations are measured with a dissolved oxygen meter and should be checked every day. There is usually a chemical test for this in water quality kits designed for aquaculture, but dissolved oxygen meters (when used correctly) are much more efficient and accurate. Dissolved oxygen measurements are reported in milligrams per liter (mg/l), parts per million (ppm), or as a percentage of saturation at that temperature (assuming standard conditions). The dissolved oxygen meter should also report temperature (degree F or degree C) because water temperature affects the amount of dissolved oxygen and other gasses the water can hold at a given pressure, i.e., the saturation level.

Fish respiration increases during and after feeding, which causes dissolved oxygen levels to drop. The amount of oxygen consumed depends on the amount of feed fed. Dissolved oxygen concentration should be measured in the fish culture tank about an hour after feeding. When you are feeding near the maximum levels (2% of body weight/day), the dissolved oxygen should be checked every day.

Carbon Dioxide - Carbon Dioxide (CO₂) is a waste product released into the water by fish. It is significant in water quality management for two reasons. First, at elevated concentrations, CO₂ tends to interfere with a fish's ability to utilize oxygen. However, experience with tilapia shows that CO₂ levels < 30 mg/L are safe. And second, production of CO₂, a weak acid, reduces the water's pH. High levels will result from poor circulation or inadequate aeration during high feeding periods. Some test kits are equipped with a CO₂ test. Usually, it is unnecessary to measure CO₂ because of the system's ability to maintain it at acceptable levels. You should simply be aware of its presence and potential effects.

pH - pH is defined as the negative logarithm of the hydrogen ion activity: $\text{pH} = -\log(\text{H}^+)$. In simpler terms, it is the measure of whether something is acidic or basic. A pH of 7 is considered neutral with all values less than 7 being acidic and values greater than 7 being basic.

It is important to understand that water pH controls the chemical equilibrium of several toxic fish metabolites, i.e., unionized ammonia and carbon dioxide. As the water's pH decreases, the shift in the total organic carbon equilibrium forms more CO₂ while the shift in the total ammonia equilibrium forms less unionized ammonia. The converse holds true as the water's pH increases. Therefore, from a management standpoint, pH can be controlled closer to 6.5 to reduce concentrations of toxic unionized ammonia and closer to 7.5 to reduce toxic carbon dioxide concentrations.

Because plants prefer a slightly acidic environment to uptake key nutrients, the pH of the water in your system should be maintained between 6.5 and 7.5. It should be measured about every other day. Several factors contribute to the general tendency for the pH in your system to steadily decline. Low or high pH values can stress fish causing decreased feeding activity and growth. See section on total alkalinity for how to adjust pH.

Total Ammonia-Nitrogen - The amount of total ammonia-nitrogen in the system should be measured at least every other day. This test measures both NH₃ (called unionized ammonia) and NH₄⁺ (called ionized ammonia) which together comprises the total ammonia-nitrogen (mg/l). The ultimate source of total ammonia is the feed administered to the fish (for more information on nitrogen cycles and forms of nitrogen see additional information). The fish metabolize the feed and excrete ammonia as a waste product. The equilibrium equation is: $\text{NH}_3 + \text{H}_2\text{O} = \text{NH}_4^+ + \text{H}_2\text{O}$. Total ammonia exists in two forms. The bulk of the ammonia exists as the ammonium ion (NH₄⁺) which is only toxic to fish at high concentrations. A small amount of the total ammonia present will be in the form of NH₃ which is toxic to fish at fairly low concentrations (it is this form which is often called Atoxic ammonia@. The amount of total ammonia that exists as un-ionized ammonia depends on the pH and temperature of the water (see Table 1 below). The higher the pH, the greater the percentage of un-ionized ammonia. The higher the temperature, the greater the percentage of un-ionized ammonia. Since there is no direct way to measure the amount of un-ionized ammonia, we must measure the amount of total ammonia and use pH and temperature to help us determine what percentage of the total ammonia will be in the toxic, un-ionized form.

Table 1 Fraction of unionized ammonia as a function of pH and temperature.

pH	Fraction of Unionized Ammonia	
	25°C	30°C
6.0	0.057	0.081
6.2	0.084	0.13
6.4	0.13	0.20
6.6	0.21	0.32
6.8	0.36	0.51
7.0	0.57	0.80
7.2	0.89	1.3
7.4	1.4	2.0
7.6	2.2	3.1
7.8	3.5	4.8
8.0	5.4	7.5

Un-ionized Ammonia - Once the concentration of total ammonia-nitrogen is known, the amount of toxic, un-ionized ammonia can be calculated and reported in mg/l. Simply refer to a table (provided with your water quality kit) that gives the percentage of un-ionized ammonia for different pH and temperatures. Find the percentage value for your pH and temperature, and multiply this by the total ammonia-nitrogen value (see the instructions in your water quality test kit for examples). Un-ionized ammonia levels of 0.2 to 2.0 mg/l will stress your fish causing depressed feeding activity. Levels higher than 2.0 mg/l can result in death.

You should note that a small change in pH can have a profound effect on the amount of un-ionized ammonia. At 25°C and a pH of 7.0, only 0.40% of the total ammonia will be un-ionized. While at 25°C and a pH of 8.0, 3.83% of the total ammonia will be in the form of toxic, un-ionized ammonia.

Nitrites - Nitrites (NO₂-) - occur as an intermediate stage in the biological decomposition of ammonia to nitrates (NO₃-). Bacteria in the gravel beds readily oxidize nitrites to nitrates if oxygen is present. Occasionally there may be an interruption in the biological processes that convert nitrites to nitrates, and nitrites will begin to accumulate in the water.

Nitrites should be checked every 3-4 days and should generally be very low (0-2 mg/l). You may notice an increase in nitrites 5-7 days after a “spike” in the ammonia levels. Nitrite concentrations of 2-10 mg/l stress fish. High nitrites (10-20 mg/l) cause “brown blood disease” in fish and can result in death (the fish will appear to be gasping for air at the surface and their blood will appear chocolate in color). Calcium chloride can be added to the system to reduce the nitrite level.

Total alkalinity - Total alkalinity is a measure of the HCO_3^- (bicarbonate) and the CO_3^{2-} (carbonate) in the water expressed as mg/l CaCO_3 . The presence of these compounds in water minimizes pH fluctuations by acting as a buffer. Potassium bicarbonate can be added to the system to increase the alkalinity. Sodium bicarbonate could also be used, but the potassium is better for the plants than sodium.

Bacteria that remove ammonia also consume bicarbonate, which causes the alkalinity in the water to decrease over time. Total alkalinity should be checked every 3 to 7 days. Measured values should exceed 50 mg/l, but do not need to be > 200 mg/L.

Turbidity - This is a measure of water clarity. Usually a secchi disc (an eight-inch white and black disc) is lowered into the water until it disappears and then brought back up until it becomes faintly visible. The depth at which it becomes visible (measured in inches) is a measure of the turbidity. A light colored coffee cup or other small object can be substituted. The turbidity should be checked each week. It is important to notice changes in turbidity. Sudden changes can indicate problems with the system. The water in tanks with high standing crops of fish will be brown in color with a secchi visibility of only 5-8 inches.

Chlorine - Tap water contains chlorine which will suffocate fish in high concentrations. Changing more than 40 % of the water in a system at one time with chlorinated tap water could stress your fish (the more organic material you have in your water, the more chlorinated water the system can tolerate). Allowing tap water to stand overnight will allow the chlorine levels to drop significantly.

Fingerling Sources

Tilapia fingerlings are available from several sources including other local producers, out-of-state producers, and (in West Virginia) local high schools. In West Virginia, several high schools raise tilapia in recycle aquaculture systems and produce fingerlings for resale. We suggest contacting your state aquaculture specialist to obtain a list of tilapia fingerling producers in your state or check the *Aquaculture Magazine's Buyers Guide* for fingerling producers in your region.

Other Issues

Due to the site specific nature of the following issues, they have been omitted from the system description: licensing requirements, detailed greenhouse design information, marketing and annual operating costs and revenue projections. Site preparation and equipment costs for the demonstration system, however have been listed in Appendix A. For further information on licensing in West Virginia see Appendix B. For additional information on greenhouse design and construction costs and we suggest that a potential producer contact his/her local extension agent or a greenhouse manufacturer. There is a significant amount of information available through extension

publications and journals on average aquaculture and greenhouse operating costs; several of which are listed in Appendix B.

APPENDIX A: PARTS LIST

Table 2 lists the equipment manufacturers used for the Natural Gas Demonstration project. Mention of specific suppliers does not imply endorsement of the company by the Freshwater Institute.

Table 2 Primary Equipment Manufactures

System Component	Company	Component Supplied
Greenhouse		
Plastic Panels	Replex Plastics PO Box 967 Mt. Vernon. OH 43050 (614) 397-5535	8mm PCSS Clear Panels and aluminum connectors
Plastic and Greenhouse Frame	Duffield Greenhouse Structures, Inc.	50' * 64' Greenhouse frame, 6 mil plastic, 30" fans, inflator fan.
Floor material	R.E. Canfield, Inc. Route 6, box 253 Buckhannon, West Virginia 26201 (304) 472-1574	One roll of Myrafab
Microscreen	Wetsel Seed Company, Inc. P.O. Box 791, Harrisonburg, VA 22801 (703) 434-6753	No-Thrips Screen
Growing Bed Materials		
Plastic Liners	Yunker Plastics, Inc. 7253 Sheridan Springs Rd., Lake Geneva, WI 53147 (414) 249-5233 TetraPond 3001 Commerce St. Blacksburg, VA 24060-6671 800-526-0650 Colorado Lining Company 1062 Singing Hills Road Parker, CO 80134 303-841-2022;303-841-5780 fax Resource Conservation Technology, Inc., 2633 N. Calvert St. Baltimore, MD 21218 800-477-7724 Environmental Protection, Inc. P.O. Box 333	

	Mancelona, MI 49659-0333 800-OK-LINER; www.geomembrane.com Watersaver Company, Inc. P.O. Box 16465 Denver, CO 80216-0465 303-289-1818; 303-287-3136 fax www.watersaver.com	
Root Zone Heating System	Bio-Energy Systems, Inc. P.O. box 191, Ellenville, NY 12428 (914) 647-6700	4' x 8' pre-assembled modules 4" oc., Set Point T' Stat, Grundfos 26-29 Circ pump
Filter Bags	Aquatic Eco-systems, Inc. 1767 Benbow Ct., Apopka, FL 32703 (407) 886-3939	300 Micron Filter Bags
Water Source storage tank	G.V.M. Inc. 374 heidlersburg Rd., Box 358, Biglerville, PA 17307 (717) 677-6197	1,100 gal. Vertical Storage Tank
float switch	Aquatic Eco-systems, Inc.	Water Level Switch
Plumbing and Irrigation 1 hp. Pumps	Hatchik Supply Co. 5260 Port Royal Rd., Springfield, VA 22151 (703) 321-7699	1 p Pak Fab Challenger Pump - medium head
950 gallon Tanks	Polytank, Inc. 62824 250 th St. Litchfield, MN 55355 (800) 328-7659	Round, conical bottom 950 gallon tank
float switch	Aquatic Eco-systems, Inc.	Water Level Switch- down
Aeration System vinyl tubing 22 Male adapters	Aquatic Eco-systems, Inc. Aquatic Eco-systems, Inc.	1 roll TV-60 Vinyl Tubing Male Adapter - 1/2 NPT x 3/8" barb
2 1/2 Hp. Sweatwater Blowers Air pressure switch 20 diffusers	Aquatic Eco-systems, Inc. Aquatic Eco-systems, Inc. Aquatic Eco-systems, Inc.	1/2 hp Sweatwater Blower Sweatwater medium-pore diffuser w/ 3/8" OD, PE
Monitoring and Control System Pump Timers	Hummert International 4500 Earth City Expwy Earth City, MO 63045	Tork Repeating Timer

Sensa Phone
Float Switches

(800) 325-3055
Aquatic Eco-systems, Inc.
Aquatic Eco-systems, Inc.

A2 Telephone Alarm System
Water Level Switch Down

Table 2 Summary of system component costs.

System Component	Total Cost (\$)
Water Resource Development	\$337.15
Greenhouse Components:	\$13,779.23
Growing Beds:	\$3,577.34
Recycle System Components:	\$4,068.032
Aeration system:	\$1,129.79
Electrical Wiring, etc. (padded)	\$2,051.43
Water Heating System:	\$825.92
Misc. Equipment:	\$1,674.15
Generator & Gas Well Hook-up:	\$9,349.9
Shipping (5% of total capital costs)	<u>\$1,839.65</u>
Estimated Total Cost:	\$38,632.592

Table 3. Detailed parts list by component with suggested price.

Component	Number of Units (#,ton,ft ² , hrs)	Unit Cost (\$)	Total Cost
Greenhouse Components:			
30' x 64' Gutter Connected Greenhouse w/ extra end Construction Labor	1	\$3,360.00	\$3,360.00
Site Prep (bulldozer)	120	\$15.00	\$1,800.00
# 57 Gravel Floor (1-1/4" limestone)	10	\$45.00	\$450.00
2" x 6" - 16' treated (for greenhouse base)	32	\$6.50	\$208.00
Miscellaneous (cement, endwall material, etc)	12	8.66	\$103.92
No-Thrips Screen (30' x 78")	195	\$0.77	\$150.15
storm doors	2	\$104.00	\$208.00
Myrafab (1 roll)	1	\$322.00	\$322.00
Shade cloth (30' x 64')	1920	\$0.10	\$192.00
Acme single thermostat	3	\$36.00	\$108.00
50 BTU Backup overhead gas heater	1	\$429.00	\$429.00
Heater vent	1	\$120.00	\$120.00
30" Exhaust Fans	2	\$795.00	\$1,590.00
Motorized Louvers	2	\$199.00	\$398.00
Inflator Fan	1	\$29.00	\$29.00
6 Mil Plastic (2x on top, sides, and ends)	1	\$720.00	\$720.00
Component	Number of Units	Unit Cost (\$)	Total Cost

	(#,ton,ft ² , hrs)		
Interior 8mm PCSS clear panel wall (6' x 10')	5	\$63.00	\$315.00
10' 8 mm aluminum H-profile connectors	4	\$13.40	\$53.60
10' 8 mm aluminum sealers	8	\$5.40	\$43.20
20" Half Fans	4	\$119.20	\$476.80
AGRO-430W lights	12	185.88	\$2,230.56
16' unlock	4	\$18.00	\$72.00
Growing Beds:			
4' X 8' Pre-assembled root zone heating module	12	\$74.03	\$888.36
Set Point T'Stat	1	\$97.86	\$97.86
Grundfos 26-96 Circ Pump	1	\$144.00	\$144.00
#8 quartz river gravel (pea gravel)	20	\$22.50	\$450.00
8" cinder blocks	216	\$0.77	\$166.32
18" Paving stones	72	\$5.15	\$370.80
white 20 mil plastic liners	12	\$27.00	\$324.00
4*8*3/4" Plywood	12	\$25.49	\$305.88
Pre. Tre. 2"*12"*8'	36	\$13.69	\$492.84
Pre. Tre. 2"*4"*8'	72	\$3.99	\$287.28
bed shims 12-5/4"*6"*8'			\$50.00
Recycle System Components:			
Construction labor	40	\$15.00	\$600.00
Round, conical bottom 950 gal tanks	2	\$353.00	\$706.00
1,100 gal vertical tank	1	\$468.63	\$468.63
1 Hp Pak Fab Challenger Pump - medium head	2	\$271.75	\$543.50
Aladdin Go Kit #5	1	\$14.75	\$14.75
PVC Piping and Fittings, misc. (padded)			\$1,500
300 Micron Filter Bags	22	\$7.10	\$156.20
Auto Telephone Alarm	1	\$389.00	\$389.00
TORK repeating timer	2	\$98.50	\$197.00
mercury float switch, pump down	2	\$31.45	\$62.90
St-8 water level switch	2	\$37.85	\$75.70
Aeration system:			
1/2 NP male adaptory (1/2 NPT x 3/8 barb)	22	\$0.36	\$7.92
Component	Number of Units (#,ton,ft ² , hrs)	Unit Cost (\$)	Total Cost

sweatwater medium pore diffuser w/ 3/8 OD	20	\$11.90	\$238.00
I roll Vinyl tubing (100')	1	\$17.25	\$17.25
1/3 hp Sweetwater blower	2	\$385.00	\$770.00
air inlet check valve	2	\$15.95	\$31.90
air pressure switch	1	\$22.50	\$22.50
chimney blocks	2	\$4.61	\$9.22
6" washable air filter	2	\$16.50	\$33.00
Electrical Wiring, etc. (padded)			
100A 20 CIR Panel	1	\$51.43	\$51.43
Miscellaneous Wiring, labor			\$2,000.00
Water Heating System:			
water pressure valve	1	\$31.70	\$31.70
42 gal con air tank	1	\$134.14	\$134.14
40 gal nat gas water heater	1	\$160.08	\$160.08
Miscellaneous pipe and fittings			\$500.00
Equipment:			
Soluable Salts Tester Pen	1	\$51.95	\$51.95
Std Calibraton Solution	1	\$12.00	\$12.00
Weighted Fish Harvest Net	1	\$65.50	\$65.50
Hanging Scale (60 lbs)	1	\$86.95	\$86.95
Generator Operator's Manual	1	\$26.00	\$26.00
portable pH meter	1	\$495.00	\$495.00
ammonia nitrogen test kit	1	\$42.50	\$42.50
nitrate test kit	1	\$42.50	\$42.50
nitrate/nitrite	1	\$77.00	\$77.00
Top loading portable scale (2000 gm x 1g)	1	\$99.50	\$99.50
DO Meter	1	\$638.75	\$638.75
Fish net	2	\$18.25	\$36.50

Table 4 PVC piping and fittings, and miscellaneous components.

Component	Number of Units	Unit Cost (\$)	Total Cost (\$)
Make-up water:			
2" 90o elbow	7	\$0.45	\$3.15
2" T	1	\$0.88	\$0.88
2" male adaptor	1	\$0.68	\$0.68
2" ball valve	2	\$14.30	\$28.60
2" pvc pipe	36	\$0.65	\$23.40
2" cap pvc	1	\$1.00	\$1.00
8" cement blocks	16	\$0.77	\$12.32
1/2" 4'*8' plywood	2	\$25.49	\$50.98
Drainage (plant beds to fish tanks):			
2" bulkhead fittings	12	\$7.79	\$93.48
2" threaded plug	14	\$0.38	\$5.32
2" male adaptor	24	\$0.80	\$19.20
2" * 5' pvc well screen	12	\$10.15	\$121.80
2" T	24	\$0.80	\$19.20
2" female adaptor	14	\$0.80	\$11.20
2" 45o elbow	8	\$1.21	\$9.68
2" fernco couplings	4	\$2.16	\$8.64
2" pvc pipe (10')	10	\$4.60	\$46.00
Irrigation:			
2" bulkhead fitting	2	\$7.79	\$15.58
2" 90o elbow	4	\$0.98	\$3.92
2" compression couplings	4	\$3.85	\$15.40
2" * 1" bushing	2	\$1.38	\$2.76
2" coupling	2	\$0.38	\$0.76
1-1/2" T	14	\$0.83	\$11.62
1" bronze ball valves	12	\$8.75	\$105.00
1" male adaptor	28	\$0.33	\$9.24
2" check valve (flapper type)	2	\$9.02	\$18.04
1-1/2" ball valve	4	\$11.53	\$46.12
1-1/2" female adaptor	4	\$0.65	\$2.60
1" pvc pipe (10')	12	\$3.40	\$40.80
1-1/2" pvc pipe (10')	9	\$3.41	\$30.69
2" pvc pipe (10')	2	\$4.50	\$9.00
conduit clips	36	\$0.30	\$10.87
Component	Number of	Unit Cost (\$)	Total Cost (\$)

	Units		
Aeration:			
1-1/2" check valves (ball-gravity type)	2	\$14.55	\$29.10
1-1/2" 90o elbow	8	\$0.62	\$4.96
1-1/2" T	20	\$0.83	\$16.60
1-1/2" 45o elbow	16	\$1.01	\$16.16
1-1/2" (sip) * 1/2" (npt) bushing	16	\$0.60	\$9.60
1/2" (npt-m) * 3/8" barb	16		
3/8" tubing	100		
air stones w/ 3/8" barb	12		
3" air lifts (w/3/8" npt * 3/8" barb)	4		
3" conduit "C" hangers & bolts	4		
Estimated Total Cost:			\$854.35

APPENDIX B: ADDITIONAL RESOURCES

System Design References:

S&S Aqua Farm

Rt. 1 Box 747

8386 County Road 8820

West Plains, MO 65775

(417) 256-5124

Geiger, Russell, A. 1990. Costs and configurations of alternative Tilapia production systems.

Masser, Michael P., J. E. Rakocy, and T. M. Losordo. Recirculating Aquaculture Tank Production Systems; Management of Recirculating Systems. Southern Regional Aquaculture Center, SRAC Publication #452.

McMurtry, M. R. 1989. Performance of an integrated aqua-olericulture system as influenced by component ratio. Doctoral Dissertation. North Carolina State University, Raleigh, NC.

McMurtry, M. R., P. V. Nelson, D. C. Sanders, and L. Hodges. 1990. Sand culture of vegetables using recirculating aquaculture effluents. *Journal Applied Agricultural Research*, 5(4): 280-284.

J. E. Rakocy, J. E., T. M. Losordo, and M. P. Masser. Recirculating Aquaculture Tank Production Systems; Integrating Fish and Plant Culture. Southern Regional Aquaculture Center, SRAC Publication #454.

Rakocy, J. E. 1989. Tank culture of tilapia. Southern Regional Aquaculture Center, Publication No. 282, Stoneville, Mississippi.

Rakocy, J.E. and J.A. Hargreaves. 1993. Integration of Vegetable Hydroponics with Fish Culture: A Review. *Techniques for Modern Aquaculture: Proceedings of an Aquacultural Engineering Conference*, 21-23 June 1993, Spokane, Washington, pp. 99-111.

Fish Production Information

Rakocy, James E. Tank Culture of Tilapia. Southern Regional Aquaculture Center, SRAC Publication #282.

Introduction to Tilapia nilotica Fingerling Production Systems. Auburn, AL: International Center for Aquaculture, Auburn University. 1991. 6pp.

El-Sayed, A.F.M. and S.I. Teshima. Protein and energy requirements of Nile tilapia *Oreochromis niloticus* fry. Aquaculture, v. 103(1), 1992, pp. 55-63.

El-Sayed, A.F.M. and S.I. Teshima. Tilapia nutrition in aquaculture. Reviews in Aquatic Science, v.5(3-4), 1991, pp. 247-266.

Appropriate Technology Transfer for Rural Areas (ATTRA)

P.O. Box 3657

Fayetteville, Arkansas, 72702

(800) 346-9140

(501) 442-9824

ATTRA is a clearing house for information on marketing, aquaculture and hydroponic vegetable production, etc.

Auburn University

Department of Fisheries and Allied Aquaculture

203 Swingle Hall

Auburn University, AL 36849

American Tilapia Association

Midwest Aquaculture Learning Center

4943 Cosgrove Rd., SW

Kalona, IA 52247

319-683-2495

Greenhouse Design and Management Information:

Greenhouse Engineering - NRAES-33

Northeast Regional Agricultural Engineering Service

152 Riley-Robb Hall

Cooperative Extension

Ithaca, NY 14853-5701

(607) 255-7654

Marketing Information

Sturdivant, Lee. 1994. Herbs For Sale. San Juan Naturals, Friday Harbor, Washington. 246 pp.

A good introduction into alternative marketing strategies for herbs and value-added herb products. The book also lists other sources of information on herb marketing, trade associations, seed sources, equipment suppliers, etc.

The following books can be obtained from:
Jonathan Kays
University of Maryland Cooperative Extension Service
18330 Keedysville Rd.
Keedysville, MD 21756
(301) 432-4492

- 1) *Non-Traditional Agriculture/Natural Resources Sourcebook In-Service Training October 1995*
- 2) *Greenhouse Management short Course, June 1996*

West Virginia Licensing Contacts:

A guide to West Virginia Aquaculture Services, Inspections and Permit Requirements can be obtained through the West Virginia Department of Agriculture:

West Virginia department of Agriculture
1900 Kanawha Boulevard, East
Charleston, West Virginia 25305-0170

Ms. Aggy Spicer
State Aquaculture Specialist
West Virginia University
Morgantown, West Virginia,
(304) 293 3392

West Virginia Division of Natural Resources
Director of Law Enforcement
(304) 558-2784

APPENDIX C ESTIMATED OPERATING COSTS

Operating costs will vary significantly by site as a function of scale of production, location, available resources, marketing strategy, and labor costs. The estimated annual operating costs for the aquaponic system presented in Table 1 are based on actual projected costs incurred by the Tallmansville demonstration system. The primary operating costs associated with the system are labor, system maintenance, marketing, miscellaneous supplies, and transportation.

Table 1 Estimated Annual Operating Costs

	\$	% of Total Operating Costs
Manager	\$10,400	46.7%
Part-time help	\$5,200	22.8%
System Maintenance	\$2,457	10.8%
Marketing	\$1,100	4.8%
Misc. Supplies	\$1,000	4.4%
Transportation	\$1,000	4.4%
Fingerlings	\$403	1.8%
Feed	\$302	1.3%
Herb Seeds	\$300	1.3%
Insurance	\$250	1.1%
well capping insurance	\$200	0.9%
Fertilizer (micro-nutrient supplement)	<u>\$100</u>	0.6%
Total Operating Costs:	\$22,763	

Approximately 70% of all operating costs come from labor costs. Labor is billed at \$10.00 per hour for management and \$5.00 per hour for a part-time position (20 hrs/wk). The manager works part time (about 20 hrs/wk) monitoring both systems and marketing product to local restaurants and wholesalers. Direct marketing to restaurants, farmers markets and retail outlets is typically more labor intensive than selling directly to wholesale outlets. The system operator has hired part-time help to collect water quality information, feed the fish, clean the fish tanks, and take care of the plants.

Marketing costs are low because of the minimal need for handling and packaging and consist primarily of telephone expenditures, advertising, and packaging and distribution of product samples. Fish are sold whole on ice and produce is sold in one pound bags to both wholesale and restaurants outlets.

System maintenance, the third largest operating cost, includes annual pump and generator maintenance. Other costs include transportation and micro-nutrient supplements. Transportation will depend on the distance of the site to market outlets, and feed and fingerling suppliers. The system operator adds micro-nutrient supplements (as a foliar spray) to compensate for the low concentration of iron and potassium in fish waste.

For those sites without access to low cost energy sources such as abandoned natural gas wells, energy (electricity and lp gas) will represent an additional operating cost. Annual energy costs (electricity and lp gas) for the Tallmansville system were estimated to be \$5,188 in the absence of free gas; \$3,000 for lp gas and \$2,188 for electricity. Electricity costs were based on the current cost of electricity per kilowatt hour (\$0.069/kw hr) to a land owner in central West Virginia and assume the use of supplemental overhead lighting. Greenhouse heating costs were based on used of a LP gas fired heating system.